

COMBi-WR

Pedestrian Reach Stacker

The first purpose built pedestrian reach stacker combining innovative features and effortless operation.

COMBiLiFT

LIFTING INNOVATION



Fork Lift Truck Association

Winner

Patented Multi-Position
Tiller Arm



combilift.com

COMBi-WR

Pedestrian Reach Stacker

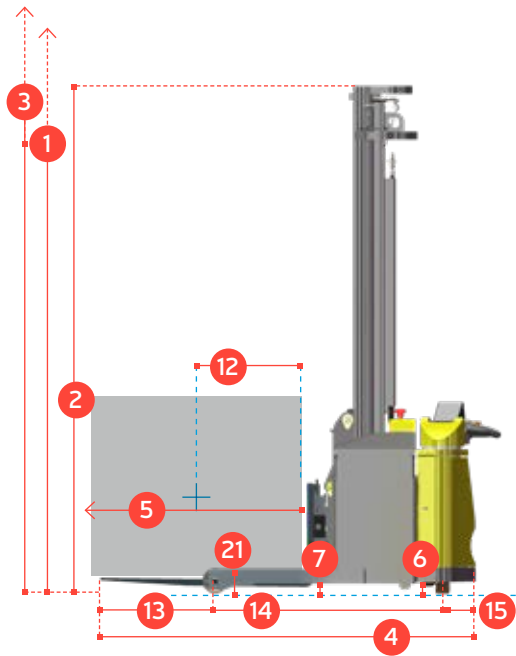
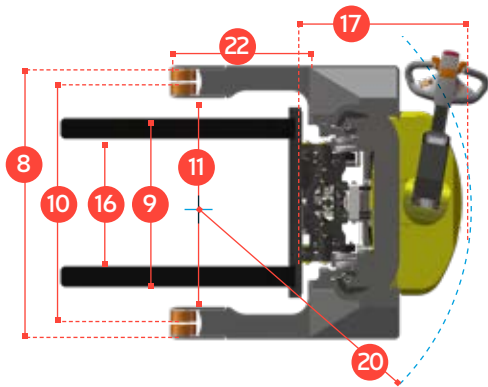

PANTOGRAPH FULLY EXTENDED

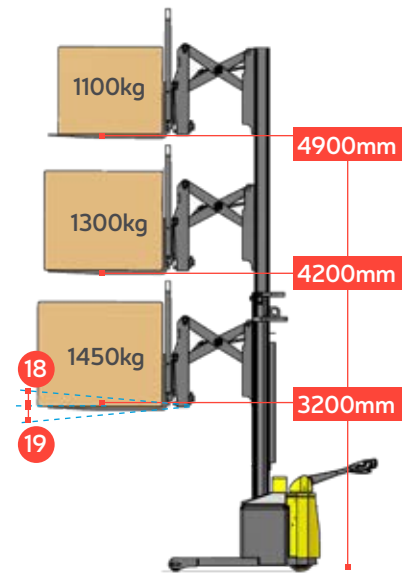

REF.	DESCRIPTION	STD.	OPTIONAL	
1a	Standard Lift Height	3000mm	4200mm	4900mm
1b	Free Lift Height	900mm	1500mm	1850mm
2	Height Mast Closed	2100mm	2700mm	3050mm
3	Max. (Mast Raised)	4200mm	5400mm	6100mm
4	Overall Length		1950mm	
5	Fork Travel		590mm	
6	Ground Clearance Under Mast		80mm	
7	Ground Clearance to Centre of Wheelbase		50mm	
8	Width		1320mm	
9	Outside Spread of Fork Arms		815mm	
10	Track Front		1165mm	
11	Frame Opening		1058mm	
12	Load Centre Distance		600mm	
13	Overhang Front		603mm	
14	Wheelbase		1172mm	
15	Overhang Back		175mm	
16	Fork Side Shift		80mm Left / 80mm Right	
17	Length from Face of Fork		880mm	
18	Fork Backward Tilt		3°	
19	Fork Forward Tilt		3°	
20	Minimum Outside Radius		1350mm	
21	Leg Height		127mm	
22	Leg Length		530mm	

A	Capacity	1450kg @ 3200mm Lift		
B	Unladen Weight	2500 kg	2600 kg	2700 kg
C	Maximum Ground Speed	6 km/h		
D	Gradeability	5%		
E	Battery Capacity	24 V / 270 Ah		
F	Fork Section	35mm x 100mm x 1070mm		
G	Front Tyre (Polyurethane)	OD 127mm / Width 75mm		
H	Rear Tyre (Vulkollan)	OD 250mm / Width 75mm		
I	Standard Colour	Yellow & Grey		
J	AC Electric Traction Motor	24V / 2.5 kW		
K	AC Electric Pump Motor	24V / 5 kW		

Superior safety with Combilift's patented Multi-Position Tiller Arm

The tiller can be turned to the left or right to allow the operator to remain at the side. This enables full visibility of the load and forks, while maintaining full steering control, providing greater awareness of the surroundings for enhanced overall safety.

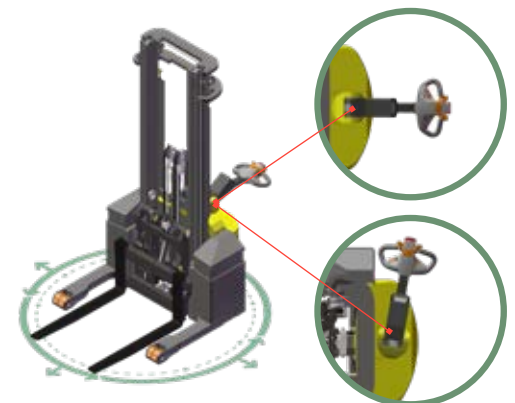

Features Include:

- Pantograph
- Power Steering
- AC Motor Technology
- 1000mm High Load Back Rest
- Rear Wheel Drive
- 80/80mm Side Shift
- Patented Multi-Position Tiller Arm

Distribute



134 Railside Rd, Henderson, AKL.
Phone: +64 9 838 0023
Email: sales@powerforklifts.co.nz

COMBILIFT HAS A POLICY OF CONTINUOUS PRODUCT DEVELOPMENT AND RESERVES THE RIGHT TO ALTER SPECIFICATIONS WITHOUT PRIOR NOTICE. SPECIFICATIONS AND/OR DIMENSIONS MAY VARY FROM THOSE ILLUSTRATED IN SOME COUNTRIES.

Standing to the side of the stacker eliminates the risk of being trapped or crushed whilst allowing the Combi-WR to operate in very narrow aisles.

Using Combi-WR

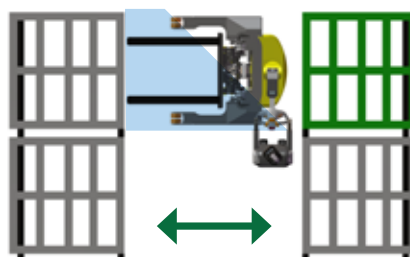

International Application No. PCT/
EP2012/067238 Multi Position Tiller