

COMBi CUBE

COMBiLiFT

LIFTING INNOVATION

With a wealth of innovative new features such as intelligent seat rotation and our proprietary Dynamic 360® Steering System, the Combi-Cube is the next generation counterbalance forklift.

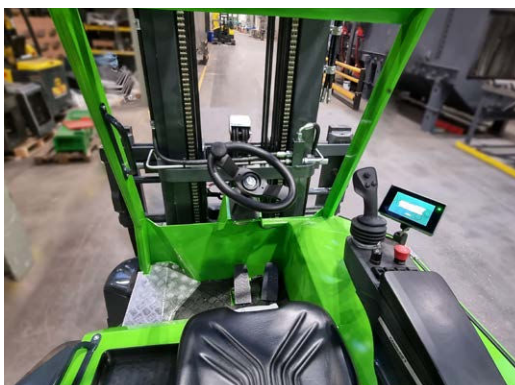

COMBI CUBE

FRONTAL
MODE

SIWARD
MODE

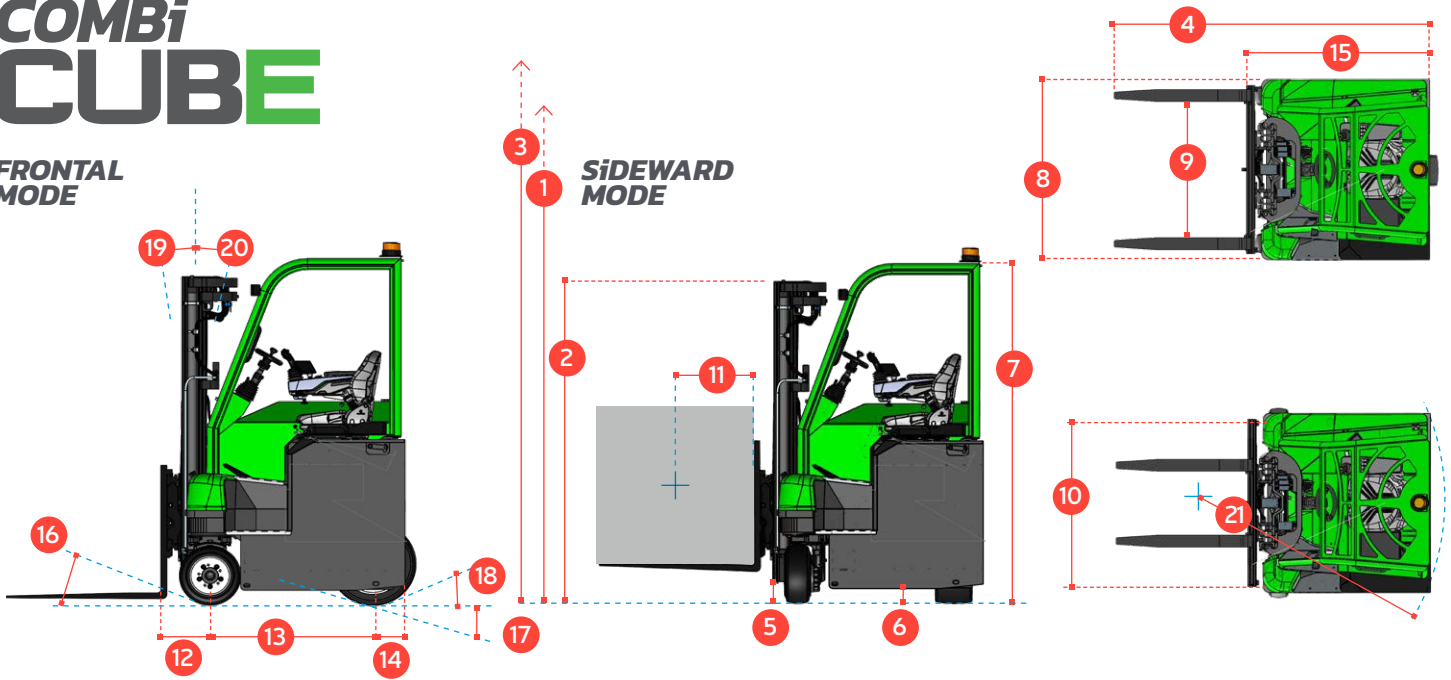

| REF. | DESCRIPTION | STD | OPTIONAL | | |
|------|--------------------------------------|--------|------------------------|--------|--------|
| 1a | Standard Lift Height | 4000mm | 4900mm | 5500mm | 6000mm |
| 1b | Free Lift Height | 0mm | 1318mm | 1518mm | 1683mm |
| 2 | Height Mast Closed | 2670mm | 2243mm | 2443mm | 2610mm |
| 3 | Max. (Mast Raised) | 4830mm | 5778mm | 6378mm | 6878mm |
| 4 | Overall Length | | 2640mm | | |
| 5 | Ground Clearance Under Mast | | 125mm | | |
| 6 | Ground Clearance to Wheelbase Centre | | 100mm | | |
| 7 | Height of Overhead Guard | | 2325mm | | |
| 8 | Width | | 1500mm | | |
| 9 | Outside Spread of Fork Arms | | 1325mm | | |
| 10 | Track Front | | 1186mm | | |
| 11 | Load Centre Distance | | 600mm | | |
| 12 | Overhang Front | | 150mm | | |
| 13 | Wheelbase | | 1048mm | | |
| 14 | Overhang Back | | 208 mm | | |
| 15 | Length From Face of Fork | | 1575mm | | |
| 16 | Approach Angle | | 30° | | |
| 17 | Ramp Angle | | 15° | | |
| 18 | Departure Angle | | 30° | | |
| 19 | Forward Tilt | | 3° | | |
| 20 | Backward Tilt | | 5° | | |
| 21 | Minimum Outside Radius | | 1400mm | | |
| A | Capacity | | 2500 kg / 3000 kg | | |
| B | Unladen Weight | | 6750 kg | | |
| C | Maximum Ground Speed | | 12 km/h | | |
| D | Gradeability | | 10% | | |
| E | Battery Capacity | | 48 V / 930 Ah | | |
| F | AC Electric Traction Motor x 2 | | 48 V / 8.7 kW | | |
| G | AC Electric Pump Motor | | 48 V / 14 kW | | |
| H | Fork Section | | 125mm x 50mm x 1065mm | | |
| I | 16 x 7 – 10.5 Front Tyre x 2 | | OD 406mm / Width 178mm | | |
| J | 22 x 10 x 16 Rear Tyre x 1 | | OD 559mm / Width 254mm | | |
| K | Standard Colour | | Green and Grey | | |
| L | Suspension Seat | | Grammer MSG 65 | | |

Intelligent Seat Rotation

The CUBE's patent pending swivel seat automatically swivels 15° to the left or right with the selected direction of travel, maximising driver visibility and reducing strain when travelling in reverse.



Features Include:

- Ergonomic cabin
- Multi-directional operation
- Powered by AC technology
- Dynamic 360° Steering
- Rubber Mounted Cabin
- Centrally Positioned Operator
- 2 Interchangeable Rollout Batteries
- Rotating Seat

2 Interchangeable Rollout Batteries



- Design Copyright Application No. - 015019216-0001
- Design Copyright Application No. - 015019216-0002

COMBILIFT HAS A POLICY OF CONTINUOUS PRODUCT DEVELOPMENT AND RESERVES THE RIGHT TO ALTER SPECIFICATIONS WITHOUT PRIOR NOTICE. SPECIFICATIONS AND/OR DIMENSIONS MAY VARY FROM THOSE ILLUSTRATED IN SOME COUNTRIES.